



# Installation, Operating & Maintenance

## COMPACT II

### 4 Piston Pneumatic Actuator

#### Sizes Included:

**C15, C20, C25, C30, C35,  
C45, C60, C75**

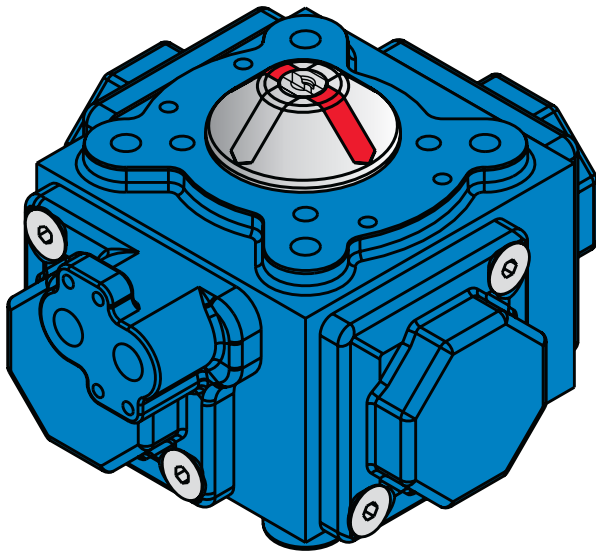

#### GENERAL

This Installation, Operating & Maintenance manual covers the instructions required for safe use of the **Compact II** pneumatic actuator. **Read the entire IOM before using this product.** ATEX certified actuators are subject to special conditions for safe use. Please refer to certificate number Cat 2 actuators 506564X.

#### WARNINGS & SAFETY INSTRUCTIONS

The user of this product must know and follow all applicable industry specifications on the safe installation and use of these types of actuators. Improper use of the product may result in injuries or property damage. Refer to Habonim **Compact II** catalogue for additional product safety information or contact Habonim.

1. Assure that the actuator is isolated from air supply or electrical ancillaries before attempting to perform any maintenance.
2. Before disconnecting the actuator from a valve, always be sure the line has been depressurized and drained. Cycle the valve a few times to relieve any pressure that could be trapped in the body cavity.
3. Utmost caution must be taken when handling the actuator. Only trained and qualified maintenance personal who have read these instructions should disassemble or assemble the actuator.
4. Before operating an actuator which is connected to a valve in the pipeline make sure you know the valve function.
5. Do not attempt to remove the actuator pistons by use of air pressure when the covers have been removed.
6. Do not leave any grip key or shaft connection attached to the actuator, or try to manually operate the actuator while it is still connected to the air pressure.
7. Use the actuator within the pressure and temperature limits indicated on the nameplate or as specified in the product catalogue and IOM.
8. The operator must follow and observe any national or local safety laws and regulations.
9. Any product warranty will be invalidated in the case of improper operation resulting from misapplication or faulty maintenance.
10. Habonim will bear no responsibility for external accessories attached to the Compact actuator.
11. The 7-year product warranty announced 1/7/08 does not apply for hi-cycle applications. For this purpose, a "hi-cycle" application is defined as one exceeding 1 cycle / minute on average measured on an hourly basis.



DEDICATED TO INNOVATION

ISSUE H-07/08

Kfar Hanassi, Upper Galilee 12305 Israel  
Tel: 972-4-6914911 Fax: 972-4-6914902  
habonim@habonim.co.il www.habonim.com

## STORAGE

The Compact actuator has been packaged to provide protection during shipment, however, it can be damaged in transport. Prior to storage, inspect the actuator for shipping damage. Keep the actuators in their original packing box during storage. It is recommended to keep the actuators in a clean and dry environment until ready for use. The actuator has two air ports, which should be plugged during storage to prevent liquids or other materials from entering the actuator during storage. If the actuators are to be stored for a long period of time before installation, it is recommended to stroke them periodically to prevent setting of the seals. Store the actuators indoors to protect them from humidity and dust.

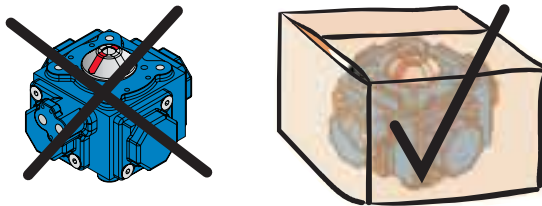

## OPERATING CONDITIONS

### Lubricants

The actuators come lubricated from the factory and under normal operating conditions do not require re-lubrication. In the event of actuator maintenance it is recommended to use the following lubricants:

For NBR O-rings use EP1.

*The lubricant is suitable for use from -20°C (-4°F) to +80°C (+176°F) with AIT/ flashpoint > (T-class + 50K).*

For Viton O-rings use Molykote 111 or OKS 1110.

*The lubricants are suitable for use from -40°C (-40°F) to +140°C (+284°F).*

For EPDM O-rings use **only** Silicone grease (i.e. Molykote 111 or OKS 110).

*The lubricants are suitable for use from -40°C (-40°F) to +140°C (+284°F).*

### Explosive Environment

The Compact II can be installed in any appropriate potentially explosive hazardous area as listed on the identification nameplate on the actuator. The Compact II is certified to **category 2** according to the ATEX Directive 94/9/EC (Equipment intended for use in Potentially Explosive Atmospheres).

For applications requiring **category 1** protection please consult with Compact representative .

### Air Supply

Use clean dry air. Other inert gases may be used such as nitrogen, argon and natural gas. Thin hydraulic oil can also be used. Do not use water as supply media.

#### Oxygen or hydrogen must NOT BE USED.

The operating medium is to be filtered to 30 micron particle size or less. Always consult with a representative of Compact for suitability and recommended practice.

Piping connected to the actuator or accessories should be fitted according to recommended instrumentation piping practice.

Prior to connection make sure all lines have no loops and are free of water, oil or other contaminants that may be trapped in

the pipes. Pipes must be flushed with air to clean the passages. Where sealants are been used for threaded connections, care must be taken to avoid excess material been forced into the actuator ports.

### Supply Pressure

The supply pressure for the Compact II actuators are as follows:

**Double-acting:** 2-8 barg (30-120 psig).

**Spring-return:** 3-8 barg (40-120 psig).

Spring-return actuators can also operate with air pressure of 2 barg (30 psig) by using the appropriate spring configuration as shown in the Compact catalogue. When sizing an actuator to available air supply, make sure you have adequate power in the actuator to allow the valve to complete its operation and leave enough power for safety margin.

### Temperature

The standard temperature limits for the Compact II actuators are -20°C (-4°F) to +80°C (+176°F). For temperatures below or above these figures special preparation and materials are required such as grease, O-rings, pinion bearings and pads.

The Compact II **maximum** working temperature is 130°C (266°F) when used with Viton O-rings and HT grease.

The Compact II **minimum** working temperature is -40°C (-40°F) when used with EPDM O-rings and LT grease.

For temperatures below -40°C (-40°F) please consult with Compact.

When used in sub-zero temperatures it is essential to use an air dryer for the supply to avoid any moisture.

Always consult with a representative of Compact II for suitability and recommended practice.

### Humidity – Corrosion

In corrosive environment or in high humidity environment it is recommended to use a Breather Block to avoid non clean air from the environment enter the actuator. (See Bulletin B370 Namur Breather Block).

### Reducers

Habonim recommends using reducers to proper control opening / closing speed of Compact actuators, especially if mounted on Butterfly valves or Dumpers.

## PRINCIPLE OF OPERATION

The Compact II actuator is a pneumatic quarter-turn Rack & Pinion actuator. Air pressure applied to the piston surface area generates thrust which transforms linear motion to rotary motion of the pinion. The Compact II has four pistons centrally located around one pinion. This means that the actuator can generate twice the torque of dual piston actuators, is lightweight, occupies minimum space and has minimal air consumption.

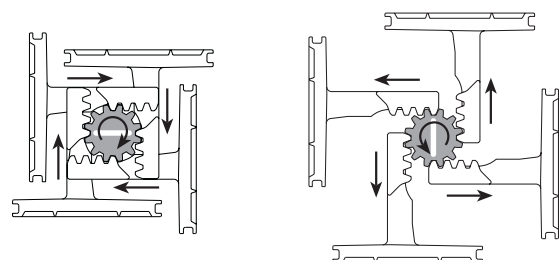

**AIR CONNECTIONS**

The actuator air connections are marked **A** and **B**.  
 Port B connects to a chain of holes to all the four pistons. The air passes into the Namur cover (or insert) and through holes which are connected to the two neighbouring pistons. Each piston receives the air flow from two directions which ensures a quick response.

In sizes C15 to C45 port **A** is to the right and port **B** to the left.

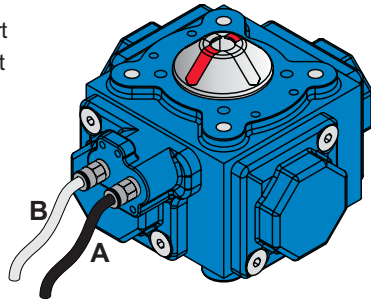

In sizes C60 and C75 the air connections are vertical where port **A** is above port **B**.

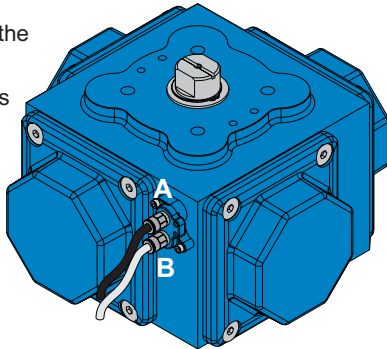

Pressure entering port **A** into the center chamber pushes the pistons outward and rotates the pinion **CCW**

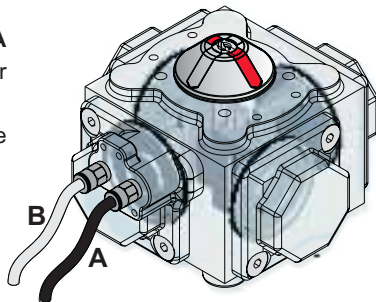

Pressure entering port **B** into the outer chambers pushes the pistons inward and rotates the pinion **CW**

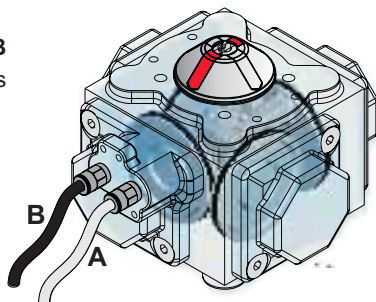

**Double Acting (DA)**

Pressure entering Port A to open:  
 Center chamber pressurized. Pistons move outward and the pinion rotates counter clockwise (CCW).

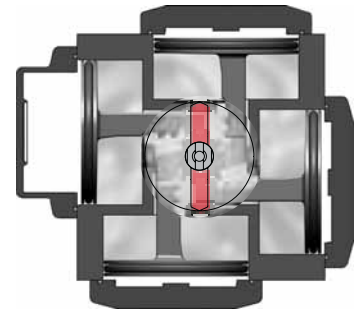
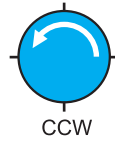

**Pressure entering Port B to close:**

Outside chambers pressurized. Pistons move inward and the pinion rotates clockwise (CW).

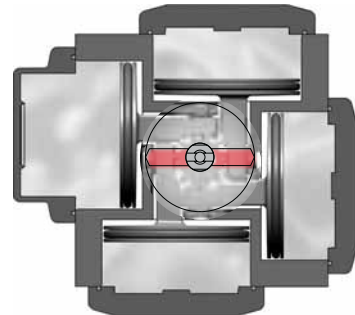
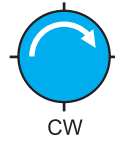

**Spring Return (SR)**

Pressure entering Port A to open:  
 Center chamber pressurized. Pistons move outward and the pinion rotates counter clockwise (CCW).  
 Springs are compressed.

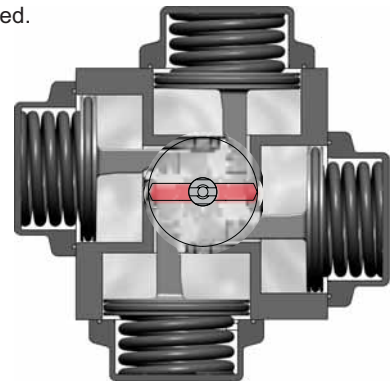
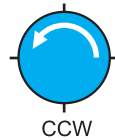

Pressure exiting Port A to close:  
 Air released from center chamber. Springs drive pistons inward.

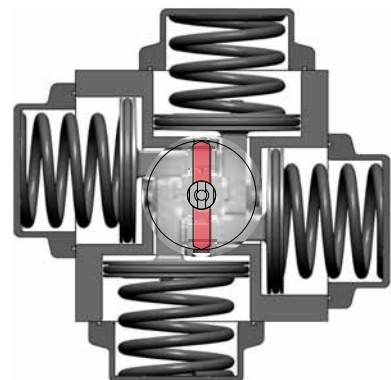

Pinion rotates clockwise (CW).

### NAMUR Solenoid Mounting

Air supply connection is done by mounting a solenoid directly onto the Namur cover which has a mounting pad conforming to the Namur standards. (Only Solenoids made to the NAMUR standard can be mounted in this way.)

The Compact II actuator can also be piped with solid or flexible tubing from remote solenoid valves.

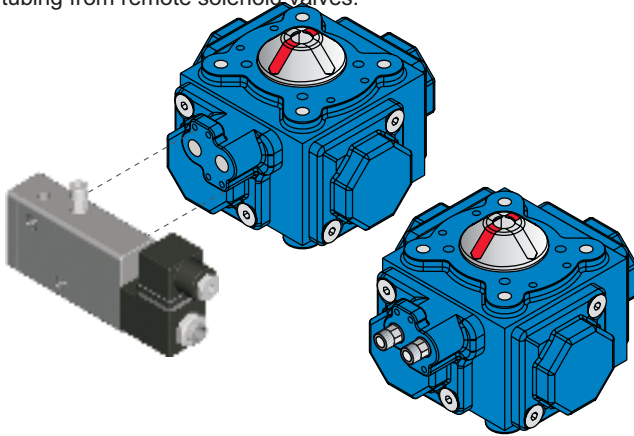

### ISO 5211 or DIN 3337

The actuator bottom flange is in accordance with ISO 5211 (or DIN 3337) international standard and incorporates a star shaped female drive for flexibility to fit various valve output shafts. The valve can be attached by a bracket or mounted directly onto the actuator, using one of the various ISO hole patterns.

### TRAVEL ADJUSTMENT

The actuator comes factory adjusted to produce 90° rotation. The rotation is restricted by the stop (13) and four adjustment screws (19) which provide fine tuning or a limiting stroke.

The screws are threaded into the actuator body and are diametrically opposed to create simultaneous and equal forces on opposite sides of the stop to eliminate off-center forces.

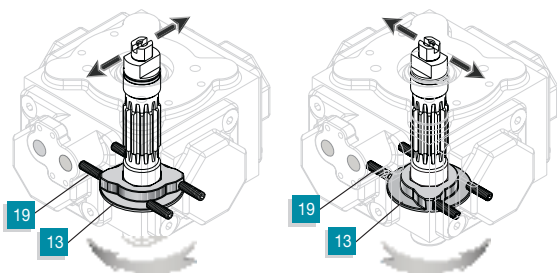

The standard stop screws allow adjustment of +/-5° in the travel limits.

Other Intermediate positions can be achieved with a longer set of stop screws which will enable travel from 0° to 20° and from 90° to 70° rotation.

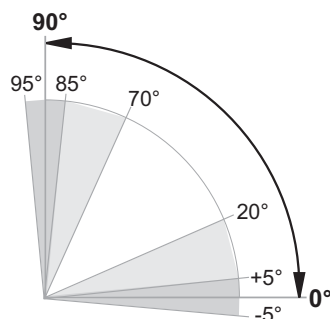

### INDICATOR & PUCK

All actuators are assembled with a highly visible indicator or puck. The indicator and puck have interchangeable "snap-on" flow direction arrows for identification of valve position.

The arrows provide any type of pattern according to the valve ports.



Use a screw driver or sharp object at the arrow head to push it out.

The puck has three position signaling inserts screws to allow signaling of any position.

The puck is screwed to the pinion Namur thread.

The indicator snaps to the pinion with its Namur interface projecting above it and enabling any ancillary to connect to the pinion.

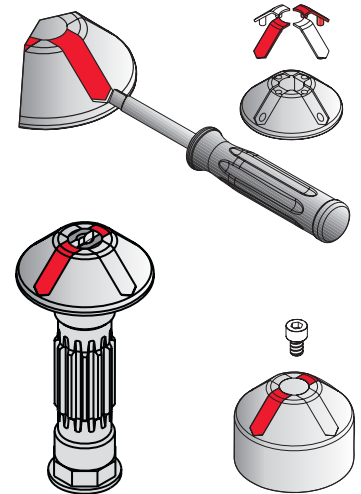

### IDENTIFICATION

Compact II actuators are supplied with a nameplate which is located on the side of the body. The information includes actuator size, model, type, spring set, threads, indicator, additional options, date of manufacture, protection rating, pressure limits and company logo.

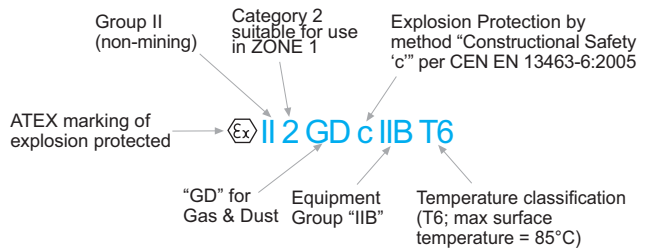
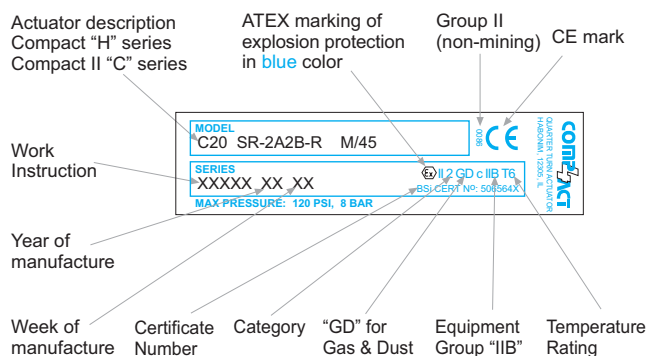

The Temperature Class 'T' of the apparatus is determined by the process fluid

## 1 DISASSEMBLY

### General

Before performing any disassembly operations make sure you read all the warnings and safety instructions in this leaflet.

Do not attempt to disassemble the actuator while it is still connected to the valve or to any ancillary.

Verify that the actuator is not pressurized. Check that the air ports are vented and spring return actuators are in the fail close position.

Work in a clean area, free of dust, debris, grease, corrosives and moisture. For security and comfort do the repairs on a table with a vice and available air supply. Clamp an adaptor to the vice and place the actuator drive on it.

Use only Metric hex head wrenches and make sure they are not blunt on the edges.

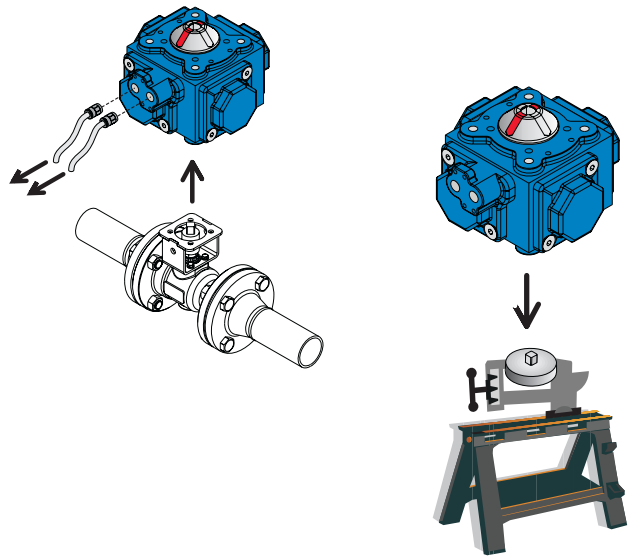

## 2 Disassembly of Double Acting Covers

**2.1** Before disassembly, mark the covers (8, 8A, 9) with the body. This is recommended to identify each cover to its original position when you re-assemble the actuator.

**2.2** Remove the cover screws (10). If in the initial rotation the screws are jammed, hit them lightly on the head with a flat pin to make them loose.

**2.3** Remove the covers making sure not to damage the O-ring seals (7, 7A, 10).

When removing the Namur cover (8A) make sure the O-ring connecting to the inner chamber is secure in its slot.

**To convert to SR actuator, go to Section 6 for assembly.**

Mark the covers

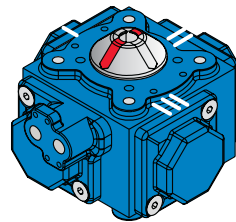

Namur cover facing air hole

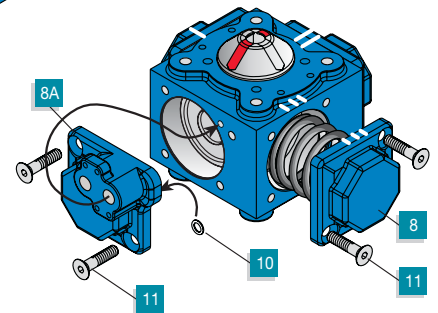

## 3 Disassembly of Spring Return Covers

**Caution: Springs in the actuator are under tension.**

**3.1** Before disassembly, mark each of the covers (8,8A,9) with the body. This is recommended to identify each cover to its original position when you re-assemble the actuator.

**3.2** Remove the cover screws in sequence by turning each opposing screw two rotations at a time. When removing the Namur cover (8A) make sure the O-ring connecting to the inner chamber is secure in its slot. Before the screws leave the threads the springs become free of tension.

If in the initial rotation the screws are jammed, hit them lightly on the head with a flat pin to make them loose. When there are 4 screws in the cover (sizes C60, C75), work on two opposing screws first and then on the second set as described before.

**3.3** Remove the covers making sure not to damage the cover seals.

**3.4** Remove the springs (4,5,6) from the cylinder and lay them together in their covers for the assembly stage.

**3.5** Follow the same routine on all four cylinders.

**To replace the spring configuration or to convert to DA actuator, go to Section 6 for assembly.**

DA covers Removal

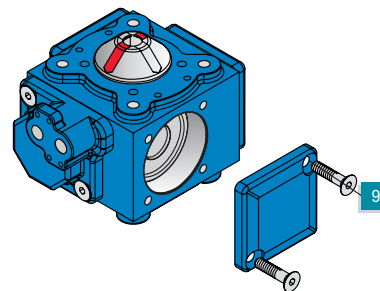

SR covers Removal

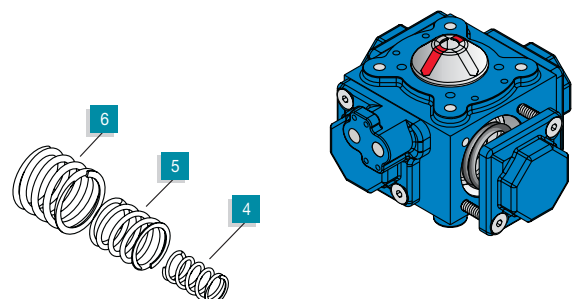

**4** **Pistons Disassembly**

- 4.1 Looking at the actuator as shown to the left, withdraw the left of each pair of stroke adjustment screws (19) approximately 6-10 mm outward. This will enable the stop to rotate beyond its 90° limit so the pistons can come out. It may require a little force to release the adjustment screws as they are assembled with a thin layer of Loctite® 221.
- 4.2 Grip the actuator body with both hands and rotate it in the CW direction to eject the 4 pistons out of their cylinders. The 4 pistons will eject out of the actuator body as demonstrated to the right.

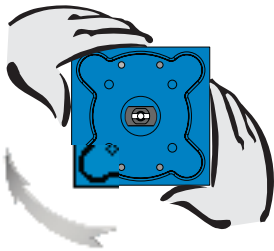

- 4.3 Remove the piston O-rings (3) by pressing them slightly from both sides of the piston, creating a loop and pull them out of their groove. Do not use a sharp object to pry them out.

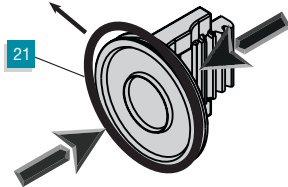

- 4.4 Push the four pads (18) in towards the pinion with a tool and remove them from body.  
Note: Usually it is not required to remove the pads.

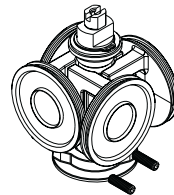
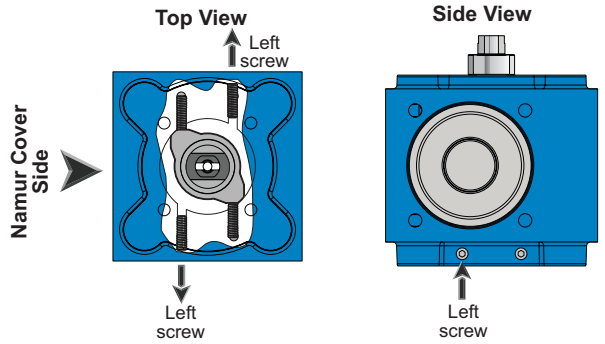
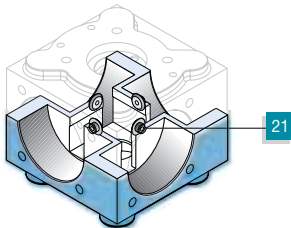

As the body is rotated CW, the pistons move out of the cylinders

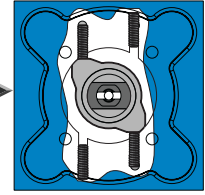

0°

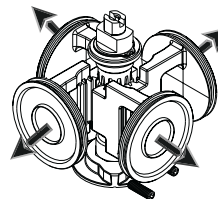

After 90° rotation the pistons are aligned with the body

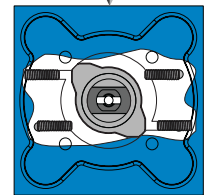

+90°

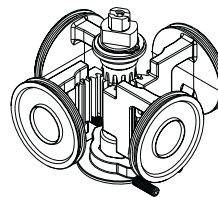

After another 30° rotation the pistons are ejected from the body

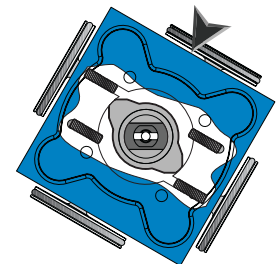

+30°

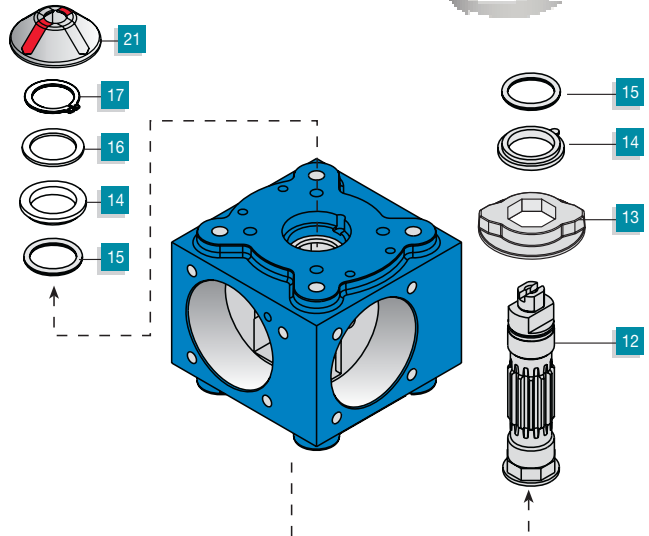

**5** **Pinion Disassembly**  
For C45 to C75 go to section 7.0

- 5.1 Remove the indicator (21). Use a two screwdrivers to pry it off the pinion. Do not apply force on the indicator.
- 5.2 Remove the circlip (17).
- 5.3 Push the pinion (12) down and remove it from the body.
- 5.4 The stop plate (13), bottom bearing (14) and pinion O-ring (15) will drop out with the pinion. There is no need to separate the stop from the pinion. Make sure the stop and pinion stay together in the same orientation they came out.
- 5.4 Remove the disc bearing (16), upper bearing (14) and O-ring (15) from the body.

**6**

**ASSEMBLY**

**General**

Before performing assembly, clean the grease in the cylinders and all the actuator parts. Check the cylinder for any scratches. The surface should be smooth and without any damage, debris, rust or other contaminants.

Apply grease to all the parts prior to assembly.

- 6.1 If you have removed the pads, push them back into their holes as shown in section 4.4.
- 6.2 If the stop (13) has been removed from the pinion (12), insert it back making sure the orientation of the two stop protrusions are at 45° to the Namur slot as shown in the drawing to the right. Use the two grooves which are cast on the stop bottom plane to identify the stop orientation.
- 6.3 Fit the thrust washer (14) and pinion O-ring (15) to the pinion (12) and stop (13).

**For C45 to C75 go to section 8.0**

- 6.4 Insert the pinion assembly into the body. Make sure that the thrust washer tongue engages to the opposing groove in the body.

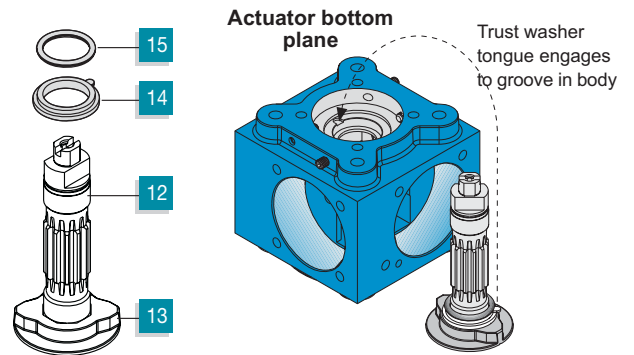
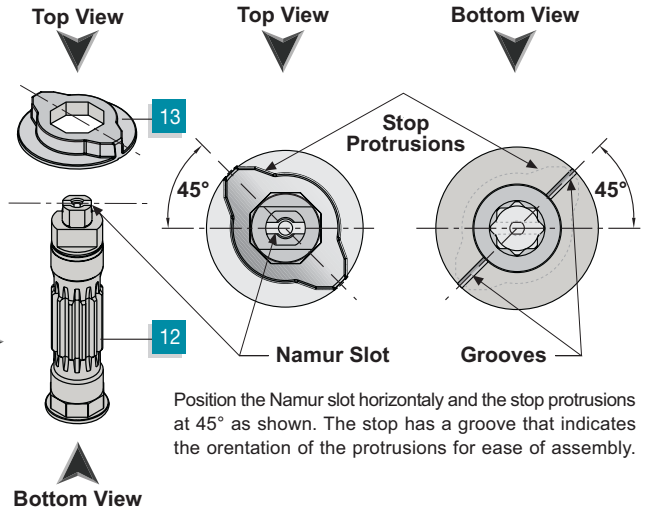
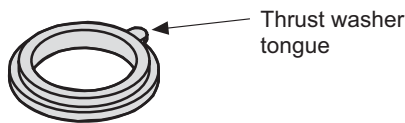

- 6.5 When inserting the pinion to the body, bring the grooves of the stop perpendicular to the adjustment screws to ensure correct angle of rotation. Rotate the pinion CCW until the protrusion flats hit the adjustment screws and the grooves line up with the threaded holes as shown below.

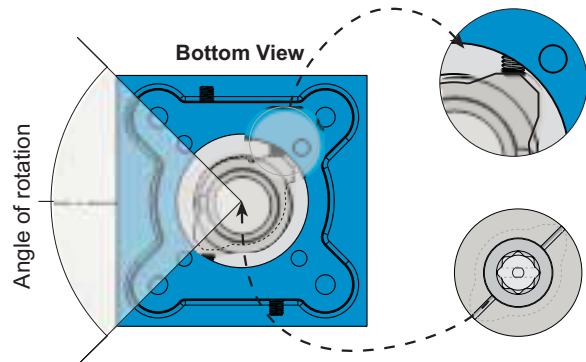
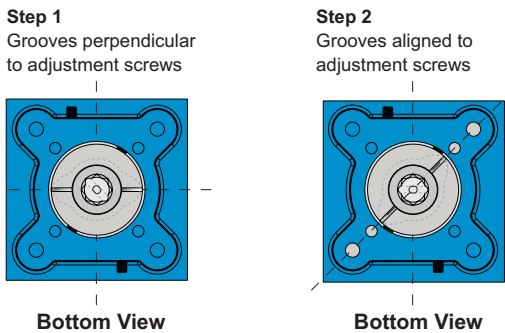

- 6.6 Fit the pinion O-ring (15), thrust washer (14) and disc bearing (16) to the pinion. Make sure that the thrust washer tongue engages to the opposing groove in the body.
- 6.7 Always use a new circlip (17). Insert it on the pinion. If the pinion does not protrude high enough, make sure that the bottom thrust bearing tongue has properly engaged into the body groove and the stop is recessed in the body. Clip the indicator (21) back on the pinion.
- 6.8 Place the assembled body with the pinion on the rig with the adaptor for inserting the pistons back in the cylinders.

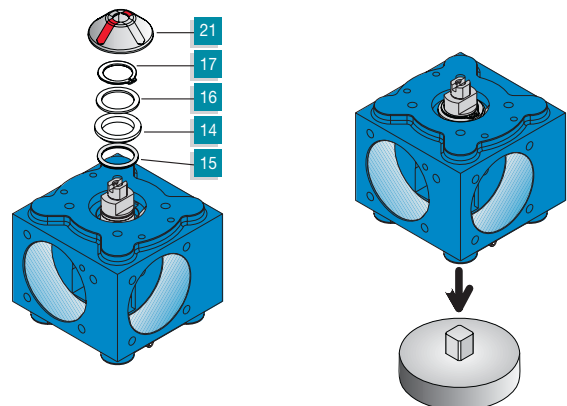

- 6.9 Looking from the top of the actuator, rotate the body 90° CW and another 40° to bring it to the position for inserting the pistons.
- 6.10 Fit the O-rings on the pistons.
- 6.11 Apply grease in the body cylinders, to the pistons groove and rack and to the piston O-rings.
- 6.12 Insert the four pistons in the cylinders, keeping the orientation of the racks so the teeth engage with the pinion teeth.

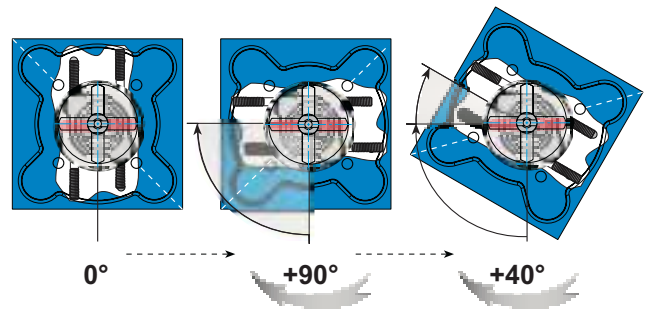

- 6.13 Holding all 4 pistons with both hands as shown, rotate the body CCW until it stops against the adjustment screws and all 4 pistons are pulled inside. Make sure all the 4 pistons have reached the same position in the cylinder.

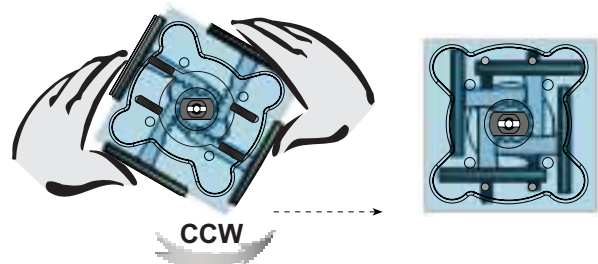

- 6.14 Rotate the body back 90° CW to the open position so the pistons are now almost flush with the actuator body. Apply a drop of Loctite® 221 to the two adjustment screws that were pulled away and screw them back until they both touch the stop. Adjust them until you visually see that the pinion flats are parallel with the body plane.

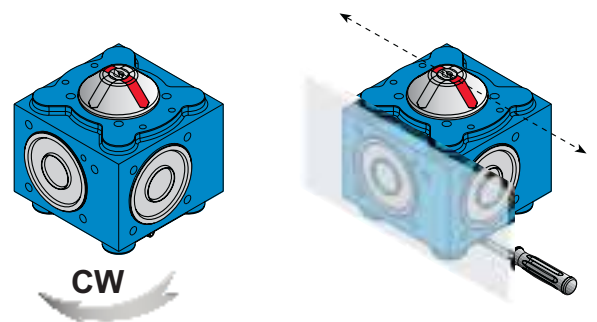

- 6.15 Rotate the body back and forth to get the pistons running smoothly in the cylinders.
- 6.16 Bring the pistons in to the close position and once again apply grease in the cylinders behind the pistons.
- 6.17 Apply grease to all the spring sets.
- 6.18 Push the cover O-rings (7) in the groove of the covers (8, 9). If needed, replace them with a new set. Notice that the Namur cover (8A) has an additional small O-ring (10) that should be in place.

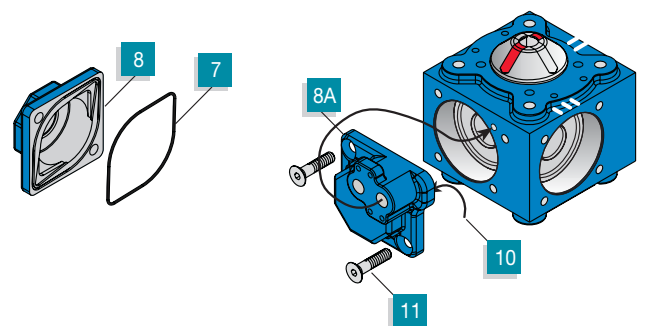

- 6.19 Lubricate the cover screws (11).
- 6.20 Assemble the Namur cover first (8A). If this is a SR actuator, place the spring set in the cover and then screw the spring cover (8).
- 6.21 Always tighten the screws in sequence.
- 6.22 Assemble the DA covers (9). Make sure the covers are put back according to your marking during disassembly.
- 6.23 Assemble the SR covers with the spring set. The screws are long enough to engage to the thread before the springs start to compress. Tighten the screws in sequence and only two turns at a time.

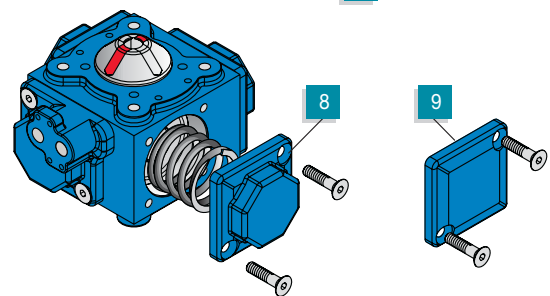

- 6.24 Finally torque the screws to the set figures in the table below.

### Actuator Screws Torque Figures

Actuator Size	Screw	NM	Lb-ft	Lb-in
C15 - C20	M5	3.5	2.5	30
C25 - C30	M8	9.0	6.5	80
C35	M10	18.0	13.0	160
C45 - C75	M12/M16	40.0	30.0	360

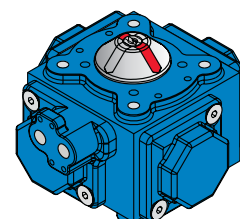

## 7 Sizes C45-C75

Sizes C45, C60 and C75 have a slightly different pinion assembly than the smaller sizes. The top bearing, O-ring disc bearing and circlip are smaller in diameter than the bottom items. The top bearing and O-ring are assembled from the bottom and not the top as with the smaller sizes. The instruction below highlights the assembly differences.

### Pinion Disassembly

- 7.1 Remove the circlip (17) and the disc bearing (16).
- 7.2 Push the pinion (12) down very carefully and remove it from the body.
- 7.3 The top bearing (14b) is inserted in the body and the top O-ring (15b) is fitted to the pinion. They should both come out with the pinion from the bottom.
- 7.4 The stop plate (13), bottom bearing (14) and bottom O-ring (15) will drop out with the pinion. There is no need to separate the stop from the pinion. Make sure the stop and pinion stay together in the same orientation they came out. The C75 has an integral stop and will not separate.

Return to section 6.0

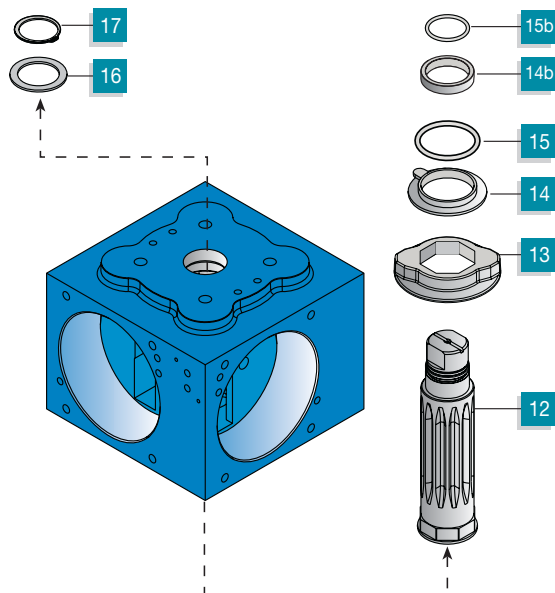

and the grooves line up with the threaded holes as shown below. See illustrations in section 6.3.

- 8.5 Fit the disc bearing (16) to the pinion.
- 8.6 Always use a new circlip (17). Insert it on the pinion. If the pinion does not protrude high enough, make sure that the bottom thrust bearing tongue has properly engaged into the body groove and the stop is recessed in the body.
- 8.7 Place the assembled body with the pinion on the rig with the adaptor for inserting the pistons back in the cylinders.

**Return to section 6.9**

## ACTUATOR TESTING

After completion of actuator assembly it is required to follow these testing procedures to ensure the actuator has been assembled correct and to minimize the risk of personal.

### Pneumatic Leak Test

The pneumatic test checks there is no leakage across the pistons or to environment.

Use commercial leak testing solution to check leakage to atmosphere. It is acceptable to allow a small amount of leakage to atmosphere. A bubble which breaks every 10 seconds is considered acceptable.

The leak testing pressure will be 80 psig (5.5 barg). Use a calibrated pressure regulator to apply pressure to the actuator.

**WARNING: Do not exceed the maximum operating pressure rating listed on the nameplate.**

Cycle the actuator at least 5 times to allow the seals to find their position before commencing with the leak test.

### Piston leakage

Any leakage across the piston is not acceptable.

- 1.0 Apply the pressure to port A and leave port B open.
- 2.0 Apply a leak testing soap solution to port B and check for leakage.
- 3.0 For DA actuators repeat this applying pressure to port B and check port A for leakage.
- 4.0 If leakage is observed, disassemble the actuator again and check the seals, surface finish and cleanliness of the internal parts to find the cause of leakage. After doing the repair work, the leakage test must be performed again.

### External leakage

For SR actuators apply the pressure to port A and leave port B open.

For DA actuators apply the pressure to port A and B. After applying pressure, wait a few seconds to let the pistons stabilize and then check for leakage. Apply the leak testing solution to the pinion output. For DA actuators apply the leak testing solution to the covers.

## 8 Pinion Assembly

- 8.1 Assemble the stop (13), bottom bearing (14) and O-ring (15) as described in section 6.2.
- 8.2 Assemble the top bearing (14b) on the pinion (12) shoulder.
- 8.2 Fit the top O-ring (15b) on the pinion in its groove. Apply grease.
- 8.3 Insert the pinion assembly into the body. Make sure that the thrust washer tongue engages to the opposing groove in the body. Be careful not to harm the top O-ring.
- 8.4 When inserting the pinion to the body, bring the grooves of the stop perpendicular to the adjustment screws to ensure correct angle of rotation. Rotate the pinion CCW until the protrusion flats hit the adjustment screws

Loctite is a registered trademark of Loctite Corp.

## PART LIST

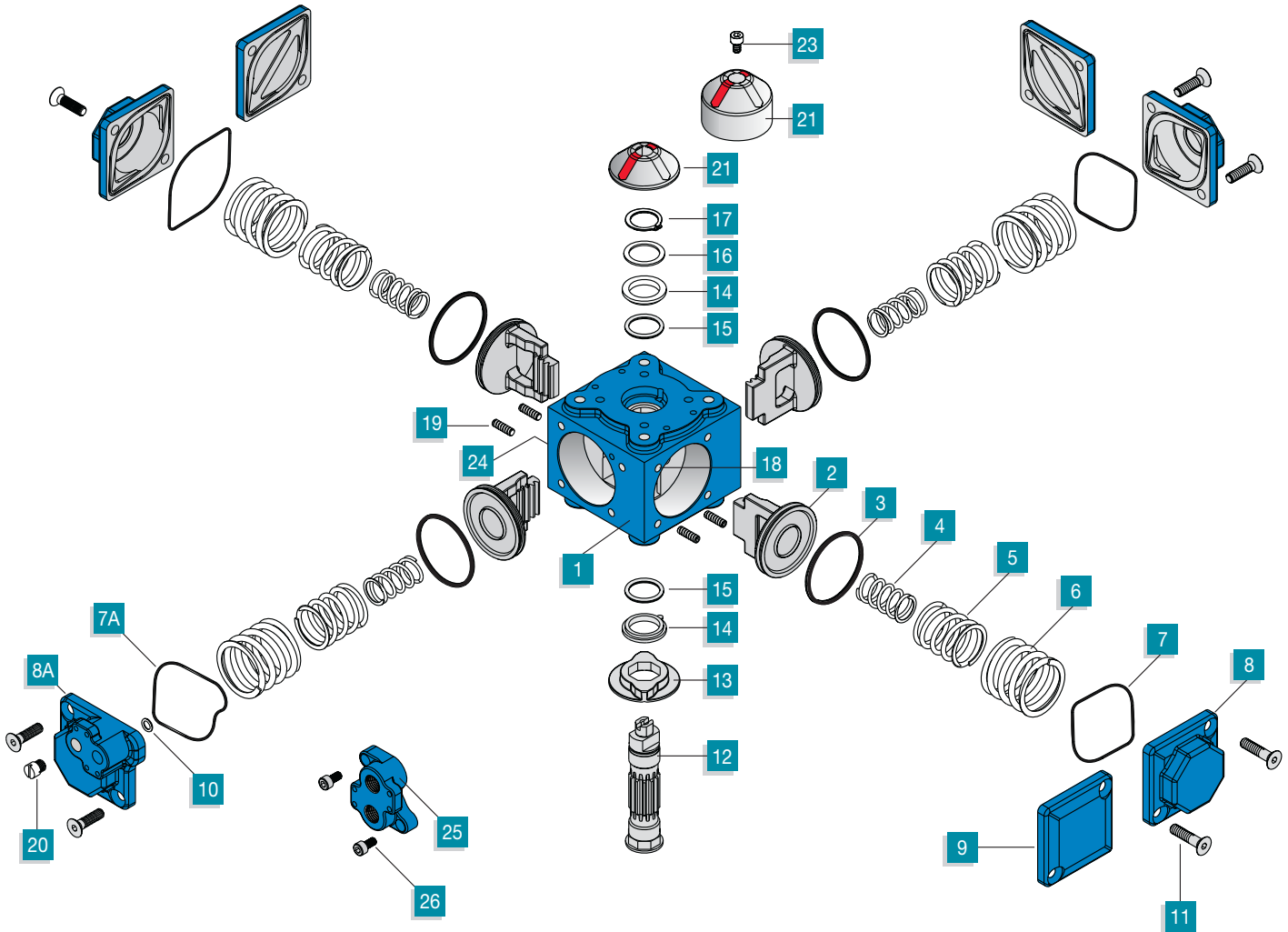

Item	Description	Material Specifications	Qty.
1	Body	AL 356-T6	1
2	Piston	AL 356/380	4
3*	Piston O-Ring	Buna N, Viton EPDM	4
4	Inner Spring	Spring steel, Painted	4
5*	Middle Spring	Spring steel, Painted	4
6*	Outer Spring	Spring steel, Painted	4
7*	Cover O-Ring	Buna N, Viton EPDM	3
7a*	Namur Cover O-ring	Buna N, Viton EPDM	1
8	Spring Return Cover	AL 380	3
8a	Namur Cover	AL 380	1
9	Double Acting Cover	AL 380	3
10*	Air Supply O-Ring	Buna N, Viton EPDM	1
11	Cover Screw	ST. ST.	8-16
12	Pinion	Steel E.N.Coated	1

Item	Description	Material Specifications	Qty.
13	Stop	ST. ST 316	1
14*	Thrust Washer	Delrin, NRG, UHMWGE	2
15*	Pinion O-Ring	Buna N, Viton EPDM	2
16*	Disc Bearing	ST. ST / Delrin	1
17*	Circlip	ST. ST	1
18*	Pad	Delrin, NRG, UHMWGE	4
19	Stroke Adjustment Screw	ST. ST	4
20	Exhaust Plug (Silencer)	Delrin, (Brass)	1
21	Indicator	Plastic (ABS), Red & White	1
22	Puck	Plastic (ABS), Red & White	1
23	Indicator Screw	ST. ST	1
24	Tag (not shown)	ST. ST	4
25	Namur Insert	AL 380	1
26	Insert Screw	ST. ST	2

\* Spare parts included in a standard repair kit